

Mass Flow Controller for Gases (MFC)



- Nominal flow ranges from 20 l_N/min up to 2500 l_N/min
- High accuracy and repeatability
- Short settling times
- Protection class IP65
- Optional: Fieldbus interface

Type 8626 can be combined with...



Type 8619

Multichannel program controller



Type 0330

3/2 way valve



Type 6013

2/2 way valve

The mass flow controller (MFC) type 8626 is suited for regulating the mass flow of high gas flows. The thermal inline sensor is located directly in the gas stream and therefore reaches very fast response times. A direct-acting proportional valve from Bürkert guarantees a high sensitivity. The integrated PI controller ensures outstanding control characteristics of the MFC.

Type 8626 can optionally be calibrated for two different gases; the user can switch between these two gases. As electrical interfaces both, analog standard signals and fieldbuses are available.

The mass flow controller type 8626 is especially designed for use in harsh environments due to a low sensitivity to contamination and the high protection class. The MFC fits for various applications, like e.g. burner controls,

heat treatment, metallurgy, food and beverage industry, environmental technology, material coatings, fuel cell technology or test benches.

Technical Data			
Nominal flow range¹⁾ (Q_{nom})	20...1500 l _N /min ²⁾ , N ₂ equivalent see table on page 2, higher flows on request	Port connection	G ¼", ⅜", ½", ¾", 1" NPT ¼", ⅜", ½", ¾", 1"
Turn-down ratio	1:50 ³⁾	Control valve	Normally closed
Operating gas	Neutral, non-contaminated gases, others available on request	Valve orifice	0.8...12 mm
Calibration gas	Operating gas or air with correcting function	K_v value	0.02...2.8 m ³ /h
Max. operating pressure (inlet pressure)	Up to max. 10 bar, depending on the orifice of the valve	Electr. connection	Socket M16, round, 8 pin and socket D-Sub HD15, 15 pin
Gas temperature	-10 to +70 °C (-10 to +60 °C with oxygen)	Additionally with:	
Ambient temperature	-10 to +45 °C (higher temperatures on request)	-PROFIBUS-DP:	Socket M12 5 pin or D-Sub 9 pin
Accuracy (after 15 min warm up time)	± 1.5% o.R. ± 0.3% F.S. (o.R.: of reading; F.S.: of full scale)	-CANopen:	Plug M12 5 pin or D-Sub 9 pin
Repeatability	± 0.1% F.S.	with RS485 version only:	Plug D-Sub 9 pin
Settling time (t_{95%})	< 500 ms	Operating voltage	24 V DC
Materials		Voltage tolerance	± 10%
Body	Aluminium (black anodized) or stainless steel	Residual ripple	< 2%
Housing	Aluminium (coated)	Power consumption	12.5 W-37 W (depending on version)
Seals	FKM, EPDM	Type of protection (with connected cables)	IP50 (RS485, RS422 versions) IP65
		Dimensions	See drawings on p. 6-9
		Total weight (examples)	2.5 kg (Al, 16 W-valve) 4.5 kg (VA, 16 W-valve)
		Mounting position	Horizontal or vertical
		Light emitting diodes (Default, other functions programmable)	Indication for
			1. Power, 3. Limit 2. Communication 4. Error

¹⁾ The nominal flow value is the max. flow value calibrated which can be controlled. The nominal flow range defines the range of nominal flow rates (full scale values) possible.

²⁾ Index N: Flow rates referred to 1.013 bar and 0 °C.

Alternatively there is an Index S available which refers to 1.013 bar and 20 °C

³⁾ With vertical installation and flow downwards the turn-down ratio is 1:10

Technical Data (cont.)			
Device variant	Analog signal version	Fieldbus version	RS485 version (only D-Sub, 9 pin)
Analog communication Input signal (set point) Input impedance Output signal (actual flow) Max. current voltage output Max. load current output	0 – 5 V, 0 – 10 V, 0 – 20 mA or 4 – 20 mA > 20 kΩ (voltage) < 300 Ω (current) 0 – 5 V, 0 – 10 V, 0 – 20 mA or 4 – 20 mA 10 mA 600 Ω	None	None
Fieldbus option (D-Sub HD15 covered with sealed plate for pins for analogue inputs/outputs not connected)	None	PROFIBUS-DP, CANopen	Modbus RTU (via RS interface)
Digital communication via adapter possible:	RS232 (supports Modbus RTU) RS485, RS422 or USB		RS485, RS422 USB
Binary inputs (Default, other functions programmable)	Three: 1. Start Autotune 2. not assigned 3. not assigned		One: Start Autotune
Binary outputs (Default, other functions programmable)	Two relay outputs 1. Limit (desired value cannot be achieved) 2. Error (e.g. sensor fault) Load capacity: max. 60 V, 1 A, 60 VA		One relay output 1. Limit (desired value cannot be achieved) Load capacity: max. 25 V, 1 A, 25 VA

Measuring Principle

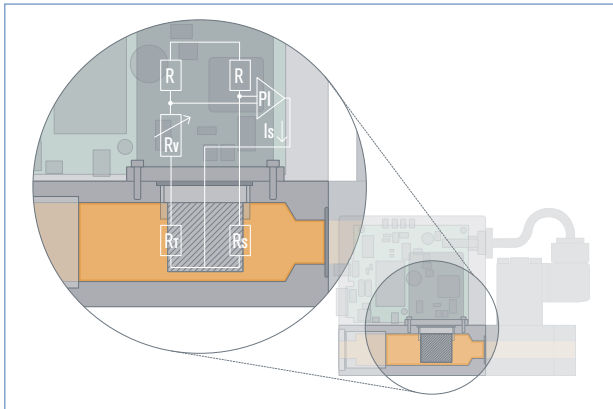

This sensor works as a hot-film anemometer in the so-called CTA operational mode (Constant Temperature Anemometer). To do this, two resistors with precisely specified temperature coefficients located directly in the media flow and three resistors located outside the flow are connected together to form a bridge.

The first resistor in the gas flow (R_1) measures the fluid temperature, while the second, low-value resistor (R_2) is heated so that it is maintained at a fixed, predefined over-temperature with respect to the fluid tem-

Nominal Flow Ranges of Typical Gases

(other gases on request)

Gas	Min. Q_{nom} [l _N /min]	Max. Q_{nom} [l _N /min]
Acetylene	20	975
Ammonia	20	1250
Argon	20	1500
Carbon dioxide	20	800
Air	20	1500
Methane	20	750
Propane	20	400
Oxygen	20	1500
Nitrogen	20	1500

perature. The heating current required to maintain this is a measure of the heat being removed by the flowing gas, and represents the primary measurement.

An adequate flow conditioning within the MFC and the calibration with high-quality flow standards ensure that the mass of gas flowing per time unit can be derived from the primary signal with high accuracy.

Notes Regarding the Configuration

For the proper choice of the actuator orifice within the MFC, not only the required maximum flow rate Q_{nom} , but also the pressure values directly before and after the MFC (p_1 , p_2) at this flow rate Q_{nom} should be known. In general, these pressures are not the same as the overall inlet and outlet pressures of the whole plant, because there are usually additional flow resistors (tubing, additional shut-off valves, nozzles etc.) present both before and after the controller.

Please use the specification sheet (p. 10) to indicate the pressures directly before and after the MFC. If these should be unknown or not accessible to a measurement, estimates are to be made by taking into account the approximate pressure drops over the flow resistors before and after the MFC, respectively, at a flow rate of Q_{nom} .

In addition, please quote the maximum inlet pressure $p_{1,max}$ to be encountered. This data is needed to make sure the actuator is able to provide a close-tight function within all the specified modes of operation.

► Please use the form on page 10 for the information about your specific requirements.

Ordering Chart for Accessories

Article	Article no.	
Connectors/Cables		
Round plug M16 8 pin (solder connection)		918299
Round plug M16 8 pin with 5 m cable		787733
Round plug M16 8 pin with 10 m cable		787734
Plug D-Sub HD15 15 pin with 5 m cable		787735
Plug D-Sub HD15 15 pin with 10 m cable		787736
Adapters⁴⁾		
RS232 adapter for connection to a computer, connection with an extension cable (item no. 917 039)		654757
Extension cable for RS232 9 pin socket/plug 2 m		917039
RS422-Adapter (RS485 compatible)		666370
USB-Adapter for D-Sub HD15		670696
USB-Adapter for D-Sub 9 pin (RS485 Version)		670693
USB connection cable 2 m		772299
Adapter for manual bus adresse settings (instad of SW)		667525
Software MassFlowCommunicator		Download from www.buerkert.com
Accessories for Fieldbus	PROFIBUS DP (B-coded)	CANopen (A-coded)
M12-Plug ⁵⁾	918198	917115
M12-socket (coupling) ⁵⁾	918447	917116
Y-junction ⁵⁾	902098	788643
T-junction	918531	(on request)
Shut-off resistor	902553	(on request)
GSD-File (PROFIBUS), EDS-File (CANopen)	Download from www.buerkert.com (see Type 8626)	

⁴⁾ The adapters serve mainly for initial operation or diagnosis. Those are not obligatory for continuous operation.

⁵⁾ The two M12 connectors as listed above cannot be used together on the same side of the Y-junction. At least one of the two M12 connection needs to be a prefabricated cable which uses typically a thinner connector.

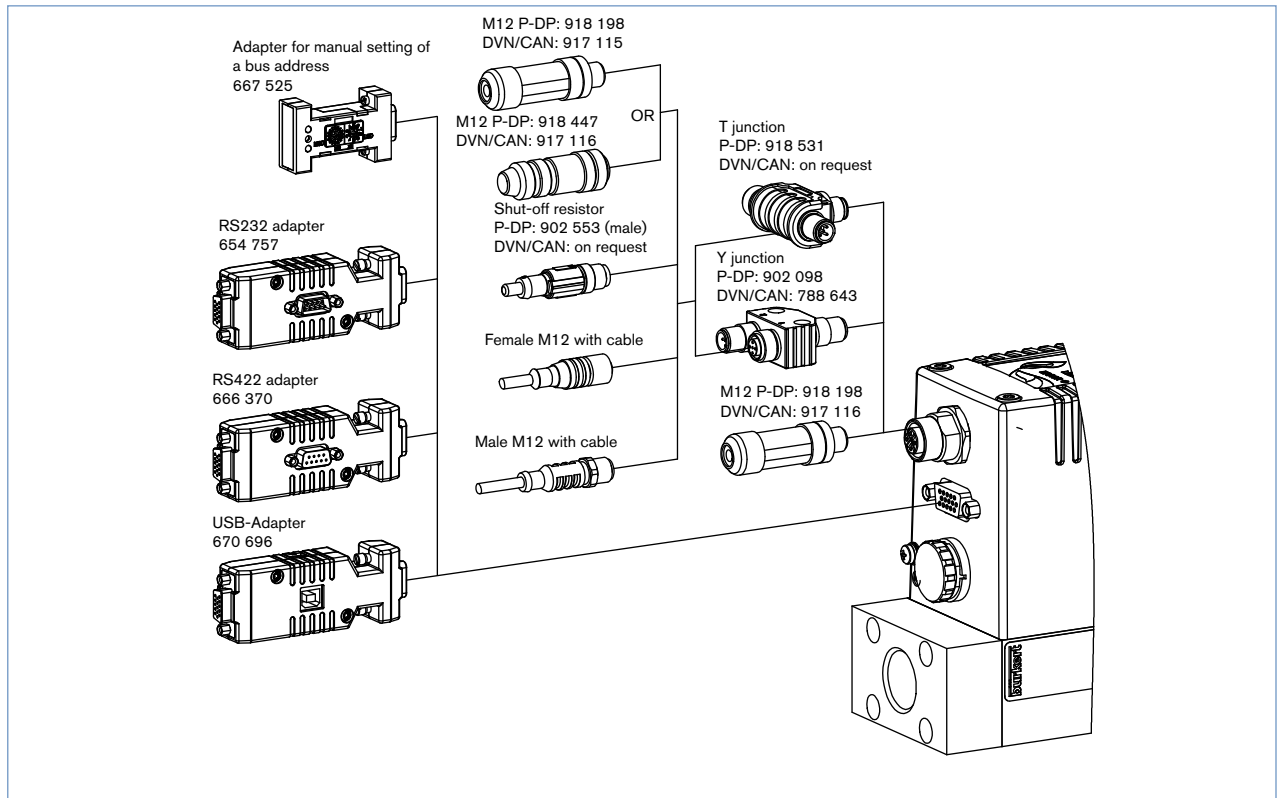

Pin Assignment

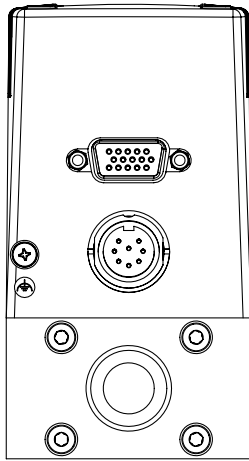

Standard

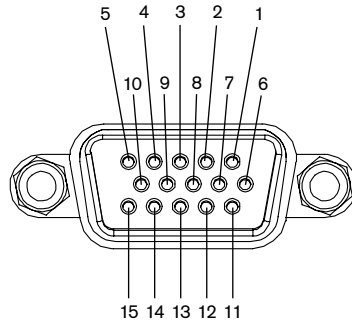

Socket D-Sub HD15

Pin	Assignment	
	Analogue Control	Bus control
1	Set value input +	N.C. ⁹⁾
2	Set value input GND	N.C.
3	Actual value output +	N.C.
4	Binary input 2	
5	12 V-Output (only for internal company use)	
6	RS232 TxD (direct connection to computer)	
7	Binary input 1	
8	GND (for binary inputs)	
9	only company internal use (do not connect!)	
10	12 V-Output (only for internal company use)	
11	12 V-Output (only for internal company use)	
12	Binary input 3	
13	Actual value output GND	N.C.
14	RS232 RxD (direct connection to computer)	
15	DGND (for RS232-interface)	

⁹⁾N.C.: not connected (not used)

Note:

- Optional Pin 1 and 2 with bus version as transmitter input possible
- The cable length for RS232/ Setpoint and flow value signal is limited to 30 meters.

Socket M16, round, 8 pin

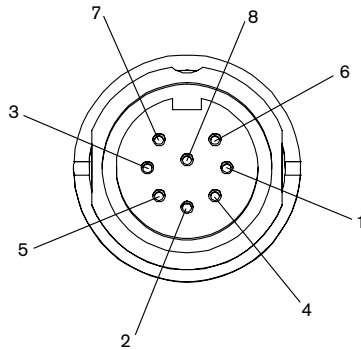

Pin	Assignment
1	24 V-Supply +
2	Relay 1 – reference contact
3	Relay 2 – reference contact
4	Relay 1 – normally closed
5	Relay 1 – normally opened
6	24 V-Supply GND
7	Relay 2 – normally opened
8	Relay 2 – normally closed

Socket D-Sub 9 pin

(only with fieldbus version)

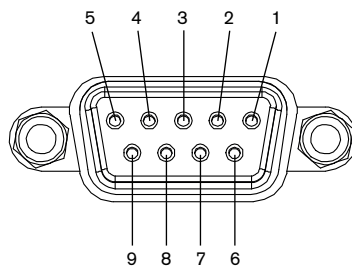

Pin	Assignment	
	PROFIBUS DP	CANopen
1	Shield	Shield
2	N.C.	CAN-L data line
3	RxD/TxD - P (B-line)	GND
4	RTS (control signal for repeater)	N.C.
5	GND	N.C.
6	VDD (only for termination resistor)	N.C.
7	N.C.	CAN-H data line
8	RxD/TxD - N (A-line)	N.C.
9	N.C.	N.C.

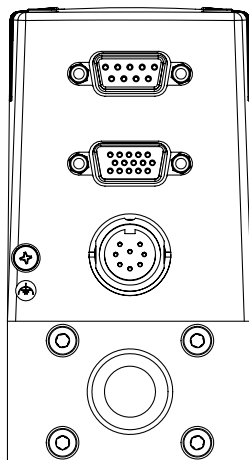

Fieldbus D-SUB

Pin Assignment (continued)

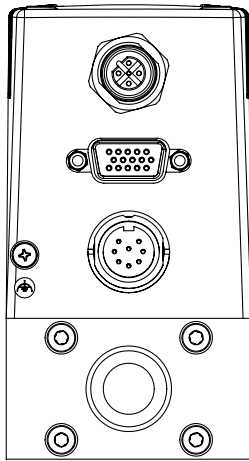

M12 Profibus

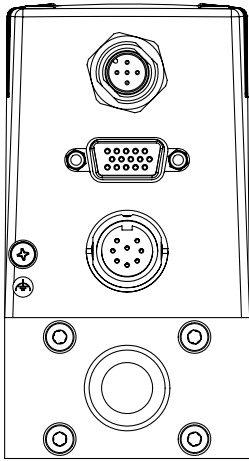

M12

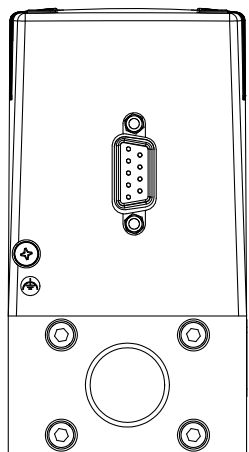

RS485 version

PROFIBUS DP – socket B-coded M12 (DPV1 max. 12 Mbaud)

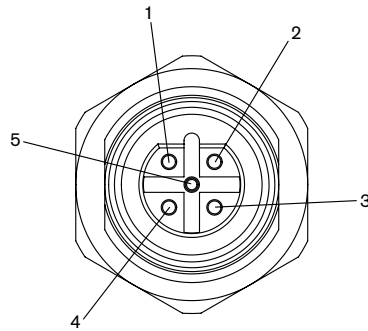

Pin	Assignment
1	VDD (only for termination resistor)
2	RxD/TxD – N (A-line)
3	DGND
4	RxD/TxD – P (B-line)
5	N.C.

CANopen – Plug A-coded M12

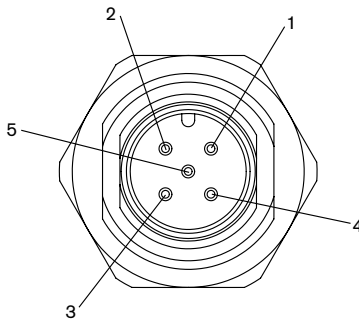

Pin	Assignment
1	Shield
2	N.C. ⁷⁾
3	DGND
4	CAN_H
5	CAN_L

⁷⁾ Optional configuration with 24 V DC possible for power supply via fieldbus connector. With this no power supply connection on round M16 plug needed.

Plug D-Sub 9 pin

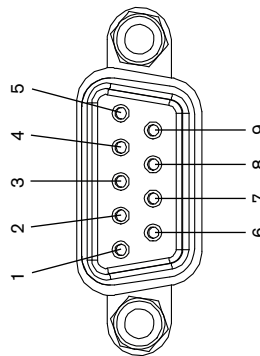

Pin	Assignment
1	Binary input (related to GND pin 2)
2	GND
3	Power supply + 24 V DC
4	Relay, normally opened
5	Relay, normally closed
6	TX+ (RS485-Y) – bridge with pin 9 at half duplex
7	TX- (RS485-Z) – bridge with pin 8 at half duplex
8	RX- (RS485-B)
9	RX+ (RS485-A)

Dimensions [mm]

MFC 8626 with valve type 2873 (9 W coil)

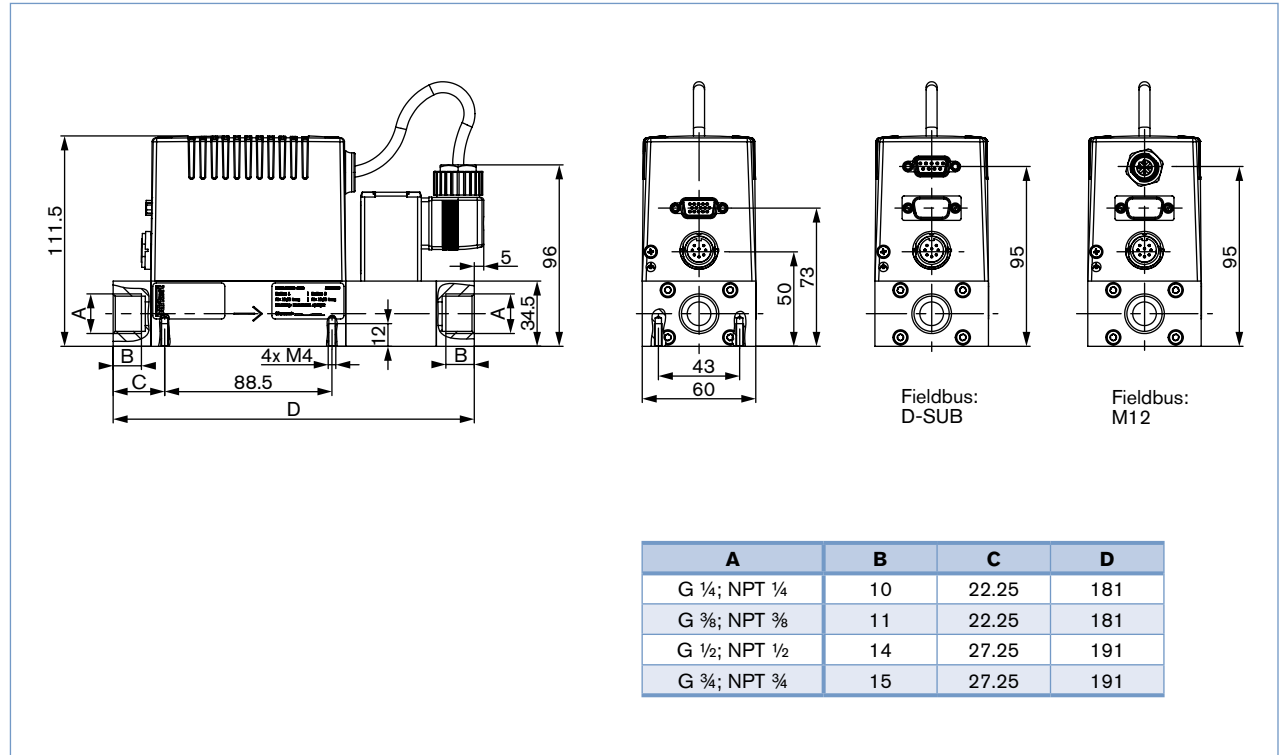

MFC 8626 with valve type 2873 (9 W coil) and base block for large nominal flow rates

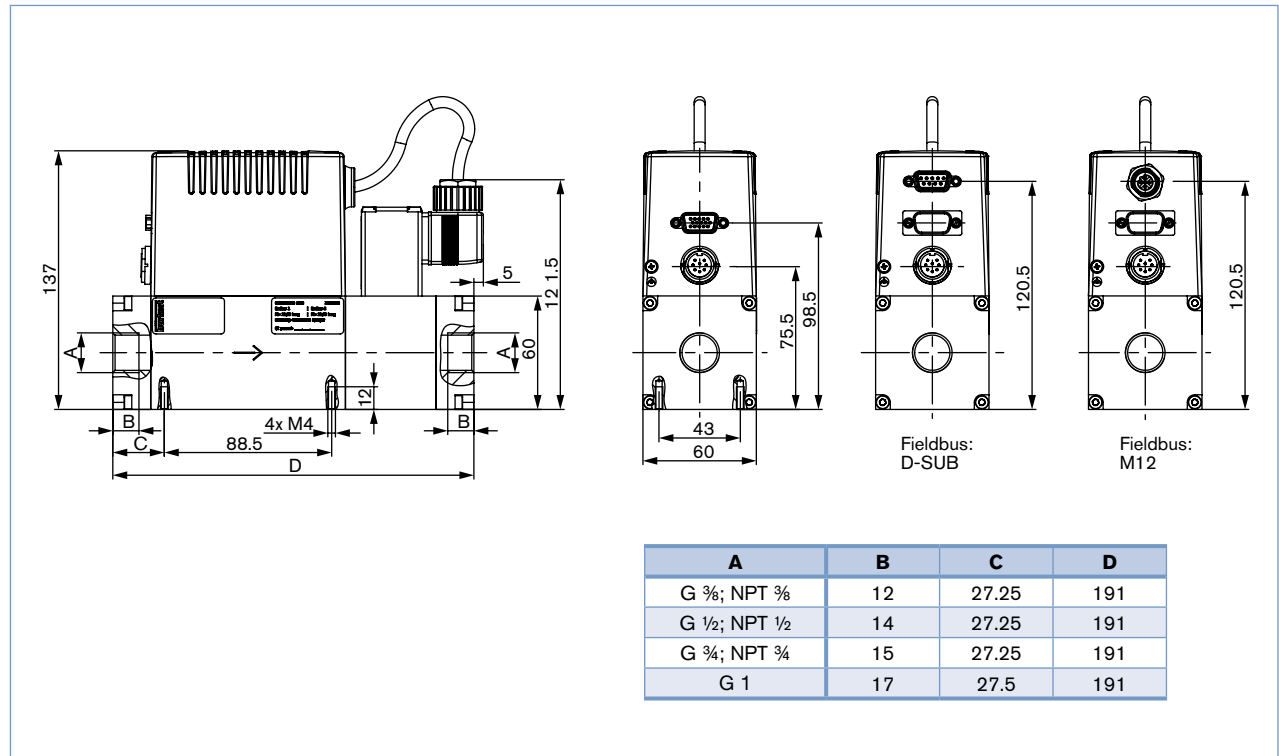

Dimensions [mm]

MFC 8626 with valve type 2875 (16 W coil)

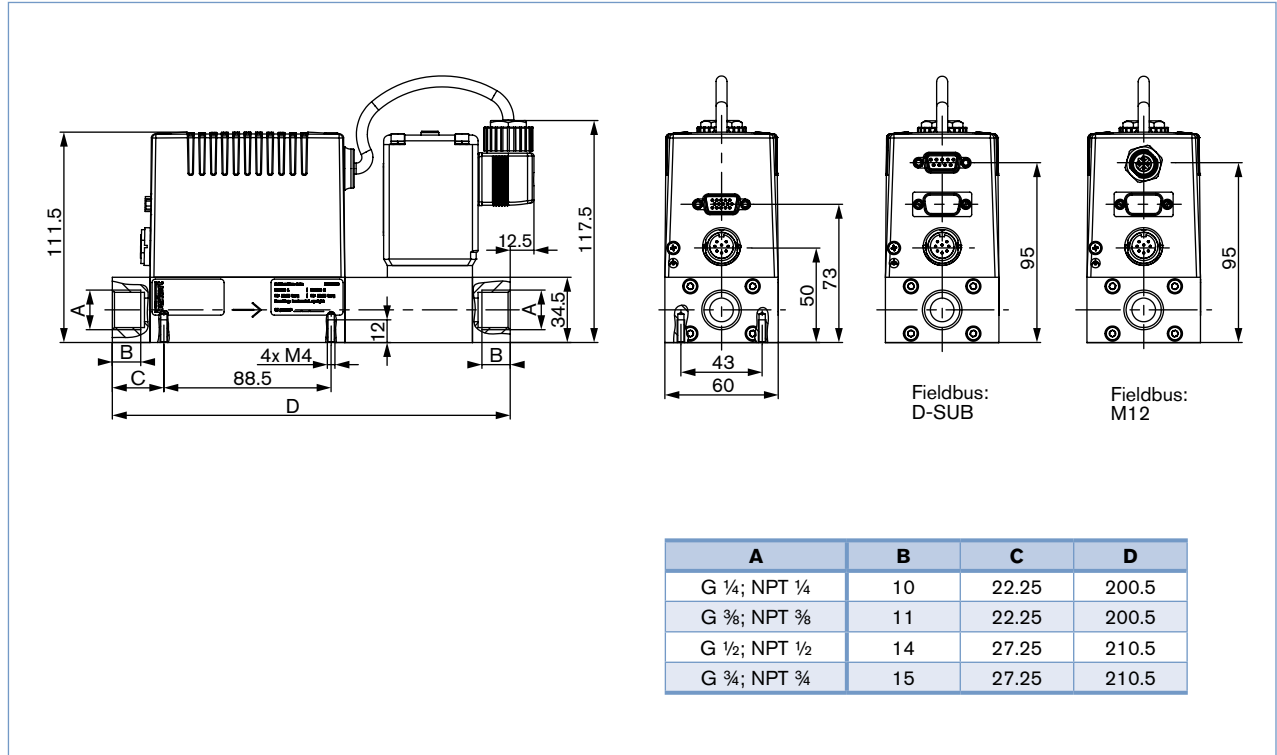

MFC 8626 with valve type 2875 (16 W coil) and base block for large nominal flow rates

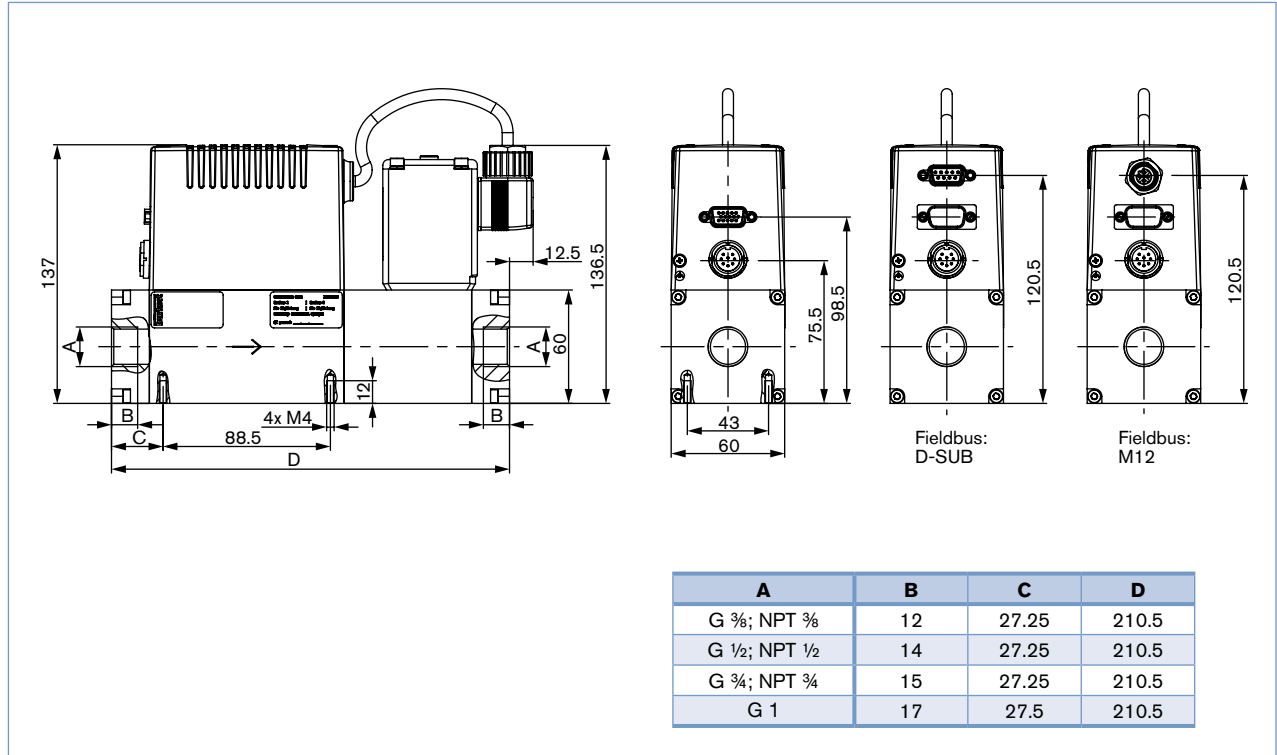

Dimensions [mm]

MFC 8626 with valve type 6024 (18 W coil)

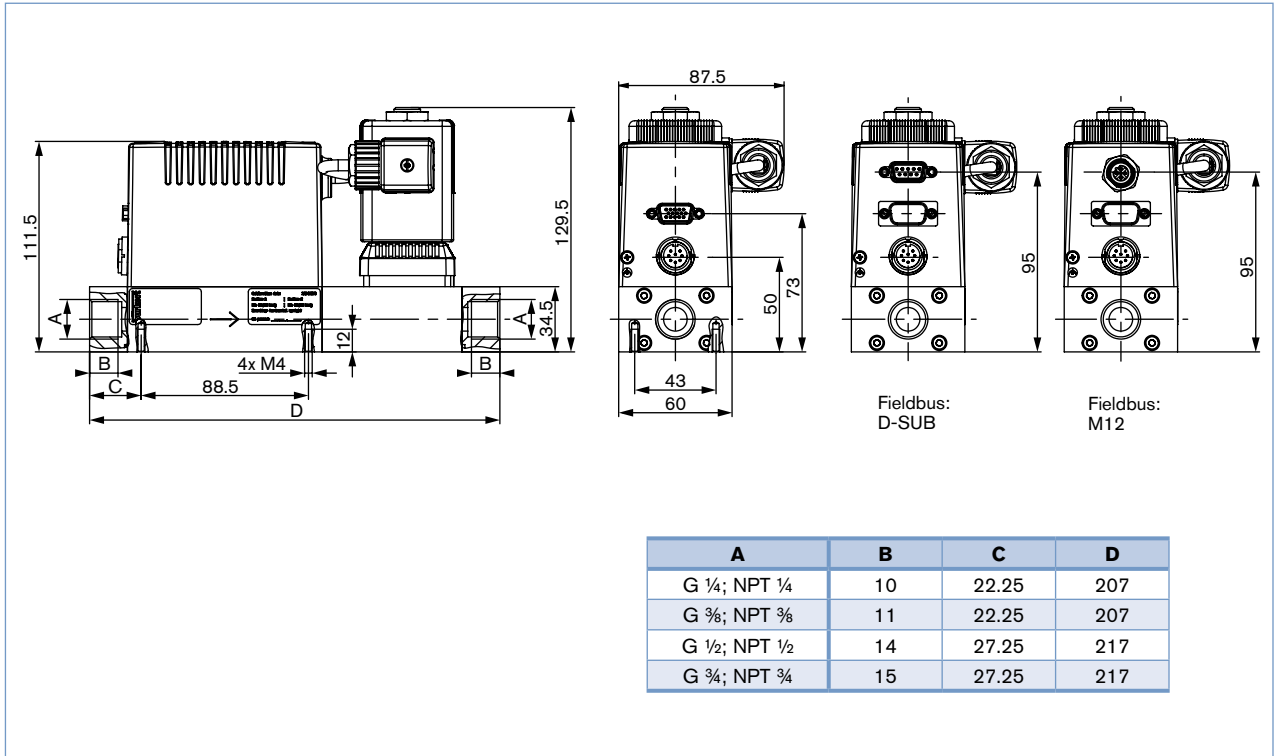

MFC 8626 with valve type 6024 (18 W coil) and base block for large nominal flow rates

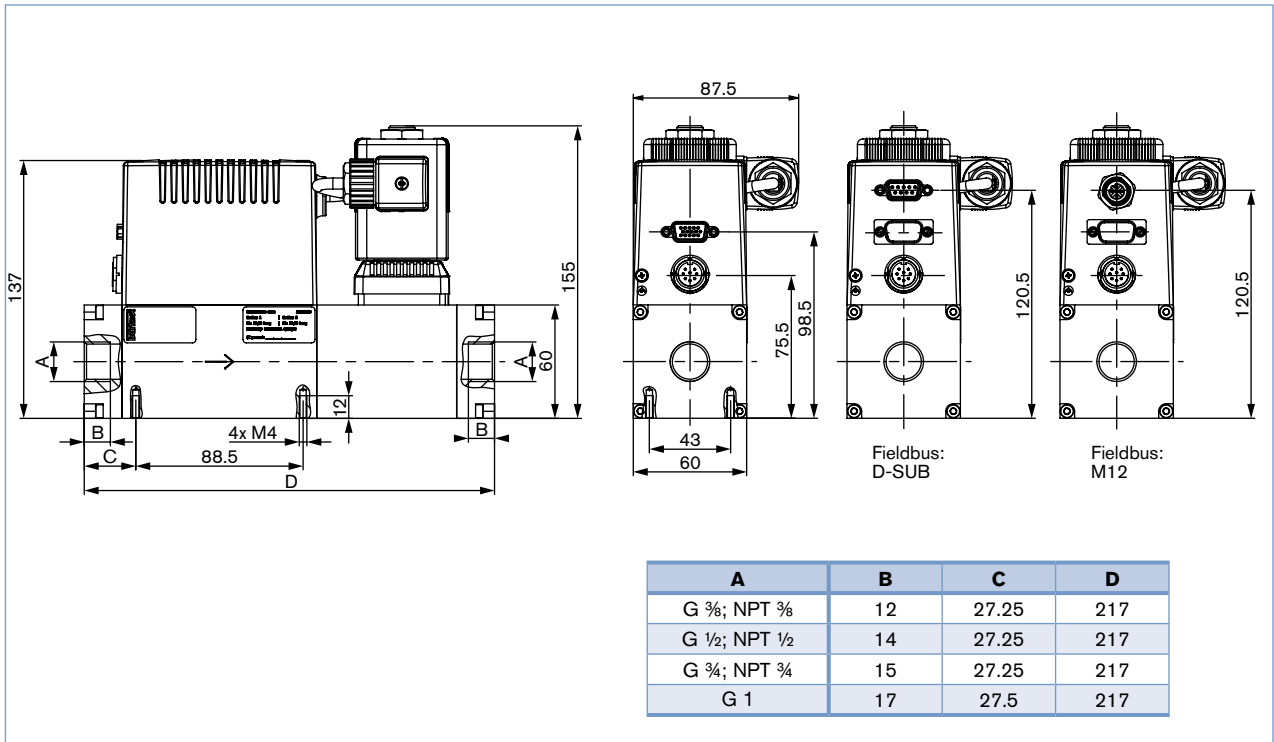

Dimensions [mm]

MFC 8626 with valve type 2836 (24 W coil)

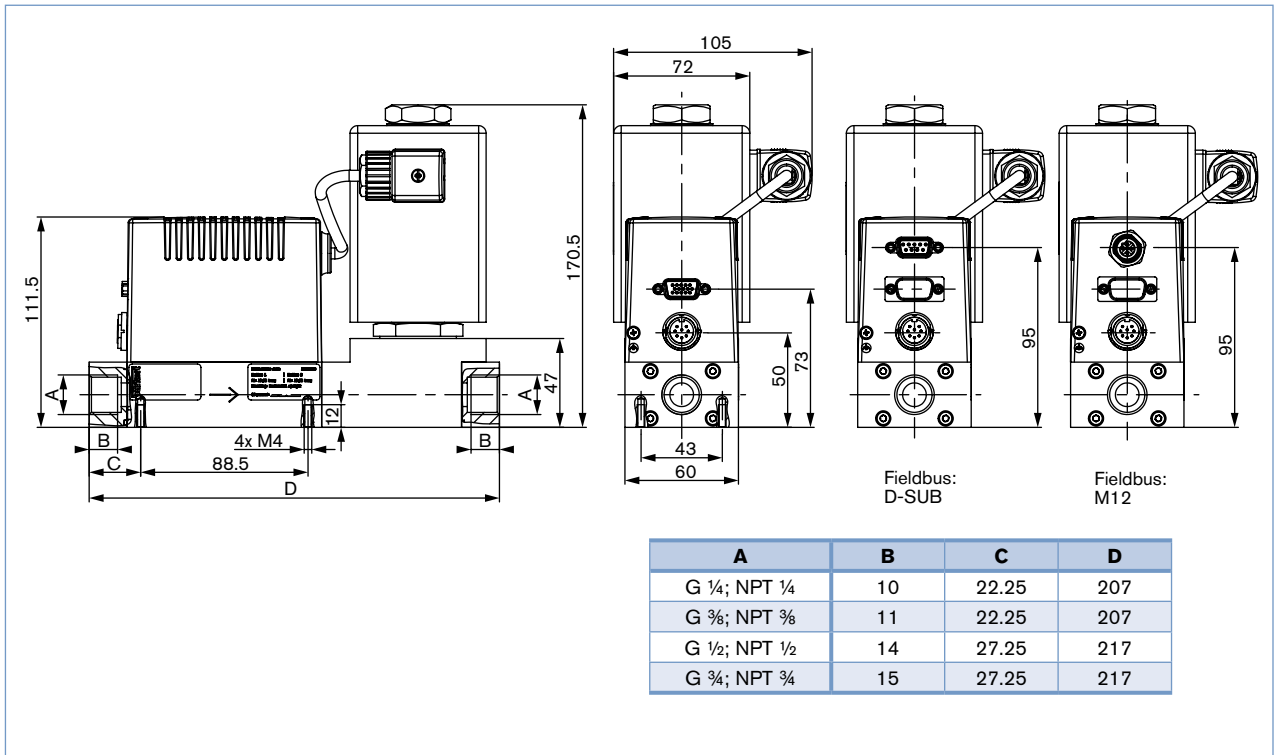

MFC 8626 with valve type 2836 (24 W coil) and base block for large nominal flow rates

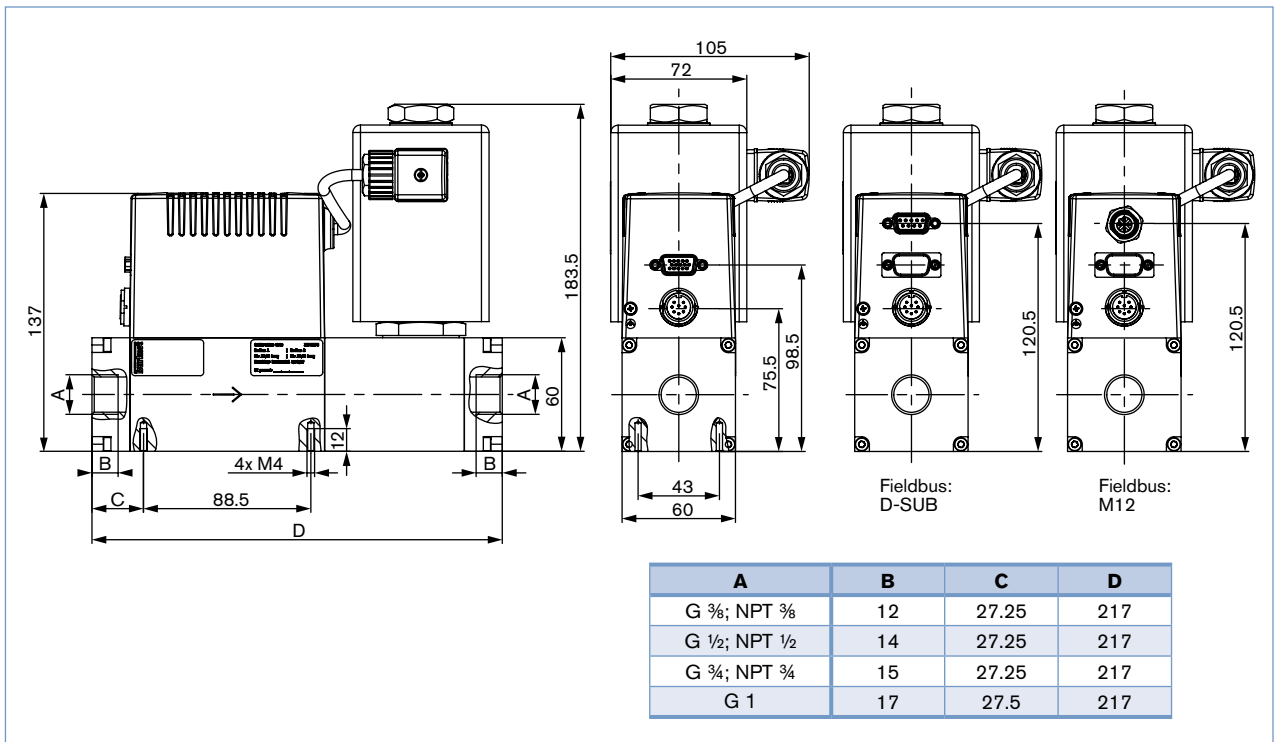

MFC/MFM Applications – Request for Quotation

Please complete and send to your nearest Bürkert sales centre

Company	Contact person
Customer No	Department
Address	Tel./Fax
Postcode/Town	E-mail

 MFC-Application MFM-Application Quantity Required delivery date

Fluid data

Type of gas (or gas proportion in mixtures)

Density kg/m³⁸⁾

Gas temperature °C °F

Moisture content g/m³

Abrasive components/solid particles no yes, as follows:

Fluidic data

Flow range Q_{nom} Min. l_N/min⁹⁾ l_S/min (slpm)⁹⁾
 Max. m_N³/h⁹⁾ kg/h
 cm_N³/min⁹⁾ cm_S³/min (scm)⁹⁾
 l_N/h⁹⁾ l_S/h⁹⁾

Inlet pressure at Q_{nom} ¹⁰⁾ $p_1 =$ bar(g) ■

Outlet pressure at Q_{nom} $p_2 =$ bar(g) ■

Max. inlet pressure p_{1max} bar(g) ■

MFC/MFM port connection without screw-in fitting
 1/4" G-thread (DIN ISO 228/1) 1/4" NPT-thread (ANSI B1.2)
 3/8" G-thread (DIN ISO 228/1) 3/8" NPT-thread (ANSI B1.2)
 1/2" G-thread (DIN ISO 228/1) 1/2" NPT-thread (ANSI B1.2)
 3/4" G-thread (DIN ISO 228/1) 3/4" NPT-thread (ANSI B1.2)
 1" G-thread (DIN ISO 228/1)
 with screw-in fitting
 mm Pipeline (external Ø)
 inch Pipeline (external Ø)

Installation horizontal, valve upright (standard) horizontal, valve on side
 vertical, flow upwards vertical, flow downwards

Ambient temperature °C

Material data

Body (base block) Aluminium (anodised) Stainless steel

Seal material FKM EPDM

Electrical data

Signals for set point and actual value	Standard signal Setpoint / Actual value	with fieldbus	with RS485
	<input type="checkbox"/> 0–5 V <input type="checkbox"/> 0–20 mA	<input type="checkbox"/> PROFIBUS DP	<input type="checkbox"/> M12
	<input type="checkbox"/> 0–10 V <input type="checkbox"/> 4–20 mA	<input type="checkbox"/> CANopen	<input type="checkbox"/> D-Sub

■ Please quote all pressure values as overpressures with respect to atmospheric pressure [bar(ü)]
8) at: 1.013 bar(a) and 0 °C 9) at: 1.013 bar (a) and 20 °C 10) matches with calibration pressure

To find your nearest Bürkert facility, click on the orange box

www.buerkert.com

In case of special application conditions, please consult for advice.

Subject to alteration.
© Christian Bürkert GmbH & Co. KG

1905/11_EU-en_00891821